

CAN@net NT 200



The Ixxat CAN@net NT 200 with two CAN channels is a multifunctional talent and a highly reliable tool in the field of CAN. It can act as a gateway between CAN and Ethernet systems, providing easy and flexible access to two independent CAN systems via LAN or over the Internet.

As a CAN-Ethernet-CAN bridge the CAN@net NT 200 allows the exchange of CAN messages between CAN systems over long distances via TCP/IP, using existing Ethernet infrastructures. The segmentation of CAN systems also increases the reliability and failure safety of the entire system.

Messages can be processed, filtered and mapped in the gateway. In addition, depending on the received messages and the status of the device or CAN bus, various actions and responses can be automatically performed. The MQTT protocol available in CAN@net NT 200 enables the information to be transmitted directly to the cloud.

FEATURES AND BENEFITS

- Easy coupling of CAN systems and devices
- Allows system expansion and tree/star topologies
- Cost savings due to simple wiring
- Increased system reliability
- 2 x CAN channels
- Line protection by galvanic isolation
- Bridging of large distances with CAN-to-Ethernet-to-CAN
- Easy remote system access
- Powerful filter, ID translation, data mapping and multiplexing functionality
- Additional programming of any kind of action rules using LUA
- MQTT support for easy cloud connection
- Powerful programming interface for Windows (VCI) as well as for Linux (socketCAN or ECI), QNX, RTX, INtime and VxWorks (ECI)

ORDER NUMBER	1.01.0332.20000
CAN channels (high-speed)	2
CAN bus interface	2 x CAN high speed according to ISO 11898-2:2016

ORDER NUMBER	1.01.0332.20000
CAN bit rates	5 kbit/s to 1000 kbit/s
CAN FD bit rates	-
CAN bus termination resistors	None
Galvanic isolation	1 kV DC for 1 sec.
CAN propagation delay (typical)	Local CAN Bridge: 25-50 μ s depending on configuration settings and CAN load. CAN-Ethernet-CAN Bridge: 4-6 ms
Messages per second (send/receive)	30000-40000 msg/s in Bridge mode
USB connector	Mini-USB 2.0 port, high-speed
LAN bit rates	10/100 Mbit/s
Ethernet connector	RJ45, twisted pair
Ethernet interfaces	1
Power supply	9 V to 36 V DC with overvoltage and polarity protection
Power consumption at 24 V	Typically 110 mA
Power consumption at 12 V	Typically 230 mA
Dimensions	114.5 x 99 x 22.5 mm
Weight	Approx. 150 g
Operating temperature	-40°C to +85°C
Storage temperature	-40°C to +85°C
Protection class	IP20
Relative humidity	10 to 95 %, non-condensing
Certification	CE, FCC, UL, UKCA
Housing material	Polyamide
LED	Transmit and defective segment (two duo LEDs, one for each segment). Power, Status, User, Ethernet (each one LED). In the Bridge mode the User LED can be configured with user defined settings via Action Rules.
Operating systems	Windows 11, Windows 10 (32/64), Windows 8 (32/64), Windows 7 (32/64), Linux

CERTIFICATES

ACCESSORIES	ORDER NUMBER
Termination adapter for CAN/CAN FD (D-Sub plug to socket)	1.04.0075.03000
CAN cable 2.0 m (D-Sub plug to socket)	1.04.0076.00180
CAN Y cable 0.22 m	1.04.0076.00001
CAN Y cable 2.1 m	1.04.0076.00002

PIN ALLOCATION

CAN CONNECTORS ① ②

⊗ 1	□	CAN-High
⊗ 2	□	CAN-Low
⊗ 3	□	CAN-GND
⊗ 4	□	Shield

POWER CONNECTOR ⑤

⊗ 1	□	V+ (+9 V to +36 V DC)
⊗ 2	□	V-
⊗ 3	□	-
⊗ 4	□	-

TECHNICAL DRAWING

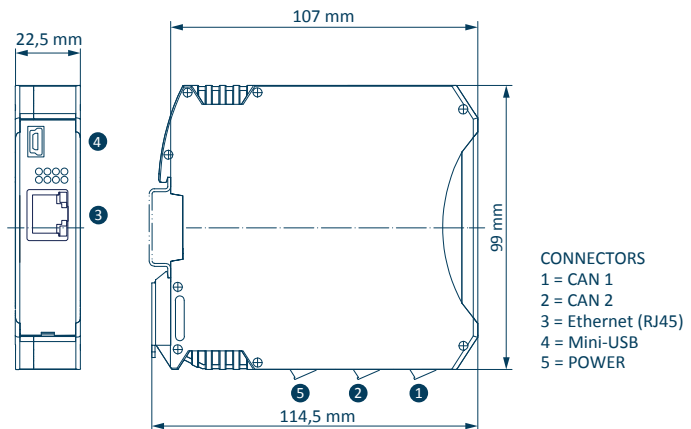

SOFTWARE SUPPORT

Configuration

The configuration of the CAN@net NT and the firmware upload is done with an intuitive to operate Windows configuration tool via USB or Ethernet. With the tool, the configuration of filter, mapping, multiplexer or translation rules can be carried out very easily, without programming skills. Further information about the configuration tool can be found on the Ixxat webpage. The configuration tool can be downloaded under www.hms-networks.com/support/general-downloads.

Drivers and programming interfaces

HMS offers for the CAN@net NT free driver packages for Windows (VCI driver), Linux (ECI driver) and various real-time operating systems. The driver packages also include a programming interface, enabling customers to develop own analysis, control or configuration applications based on the Ixxat CAN@net NT. File downloads and further information can be found on the Ixxat website.

Tools

For analysis and configuration HMS offers powerful tools which can be used in combination with the CAN interface. For Windows, the canAnalyser Mini is included in the scope of delivery (part of the driver download package). Further information about the tools as well as Demo/Trial versions are available on the Ixxat webpage.